

6 T885 PCB Information



Caution: This equipment contains CMOS devices which are susceptible to damage from static charges. Refer to [Section 1.2](#) in Part A for more information on anti-static procedures when handling these devices.

Note: To ensure that the T885 will continue to meet its performance specifications, you must tighten the bottom cover screws to the correct torque, and in the correct order, as described in [Section 2.4](#) in Part A.

This section provides the following information on the T885 receiver:

- parts lists
- grid reference index
- PCB layouts
- circuit diagrams.

Section	Title	IPN	Page
6.1	Introduction		6.1.3
6.2	T885 Receiver PCB	220-01595-02	6.2.1

6.1 Introduction

Product Type Identification

You can identify the receiver type by checking the product code printed on a label on the rear of the chassis (product codes are explained in [Section 1.3](#) in this Part of the manual, and [Figure 1.1](#) in Part A shows typical labels). You can further verify the receiver type by checking the placement of an SMD resistor in the table that is screen printed onto the top side of the PCB, similar to the example drawn below. In this example, the resistor indicates that the product was built as a T885-10-XXXX.

885-	■ ■	PRODUCT TYPE			
885-30	■ ■	■ ■	885-10	■ ■	885-20
885-35	■ ■	■ ■	885-13	■ ■	885-23
PRODUCT TYPE		■ ■	885-15	■ ■	885-25

Note: The only function of this resistor is to indicate the product type. It has no effect on the circuitry or operation of the receiver.

PCB Identification

All PCBs are identified by a unique 10 digit “internal part number” (IPN), e.g. 220-12345-00, which is screen printed onto the PCB (usually on the top side), as shown in the example below:



The last 2 digits of this number define the issue status, which starts at 00 and increments through 01, 02, 03, etc. as the PCB is updated. Some issue PCBs never reach full production status and are therefore not included in this manual. A letter following the 10 digit IPN has no relevance in identifying the PCB for service purposes.

Note: It is important that you identify which issue PCB you are working on so that you can refer to the appropriate set of PCB information.

Parts Lists

The 10 digit numbers (000-00000-00) in this Parts List are “internal part numbers” (IPNs). We can process your spare parts orders more efficiently and accurately if you quote the IPN and provide a brief description of the part.

The components listed in this parts list are divided into two main types: those with a circuit reference (e.g. C2, D1, R121, etc.) and those without (miscellaneous and mechanical).

Those with a circuit reference are grouped in alphabetical order and then in numerical order within each group. Each component entry comprises three or four columns, as shown below:

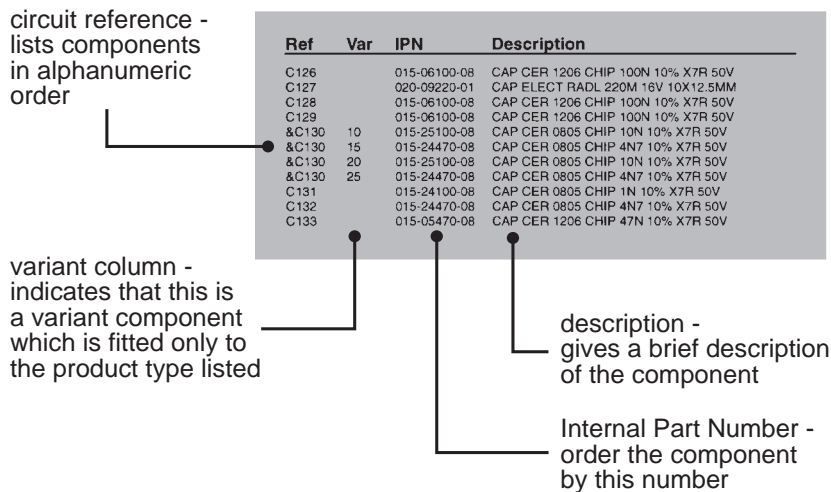

The mechanical and miscellaneous section lists the variant and common parts in IPN order.

Parts List Amendments

At the front of the parts list is the Parts List Amendments box (an example of which is shown below). This box contains a list of component changes which took place after the parts list and diagrams in this section were compiled. These changes (e.g. value changes, added/deleted components, etc.) are listed by circuit reference in alphanumeric order and supersede the information given in the parts list or diagrams. Components without circuit references are listed in IPN order. The number in brackets at the end of each entry refers to the Tait internal Change Order document.

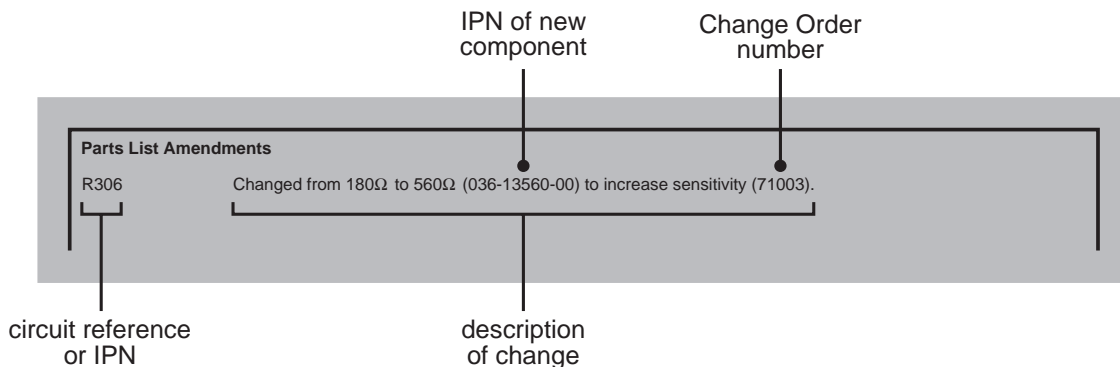

Variant Components

A variant component is one that has the same circuit reference but different value or specification in different product types. Where two products share the same PCB, the term “variant” is also used to describe components unplaced in one product. Variant components have a character prefix, such as “&”, “=” or “#”, before the circuit reference (e.g. &R100).

The table below explains the variant prefixes used in T800 Series II products:

If the variant prefix is. . .	the component will. . .
&	change according to channel spacing
=	change according to frequency stability
#	change according to frequency range
%	change or be placed/unplaced for special applications
*	be unplaced in one product (where two products share the same PCB)

Grid Reference Index

This section contains a component grid reference index to help you find components and labelled pads on the PCB layouts and circuit diagrams. This index lists the components and pads in alphanumeric order, along with the appropriate alphanumeric grid references, as shown below:

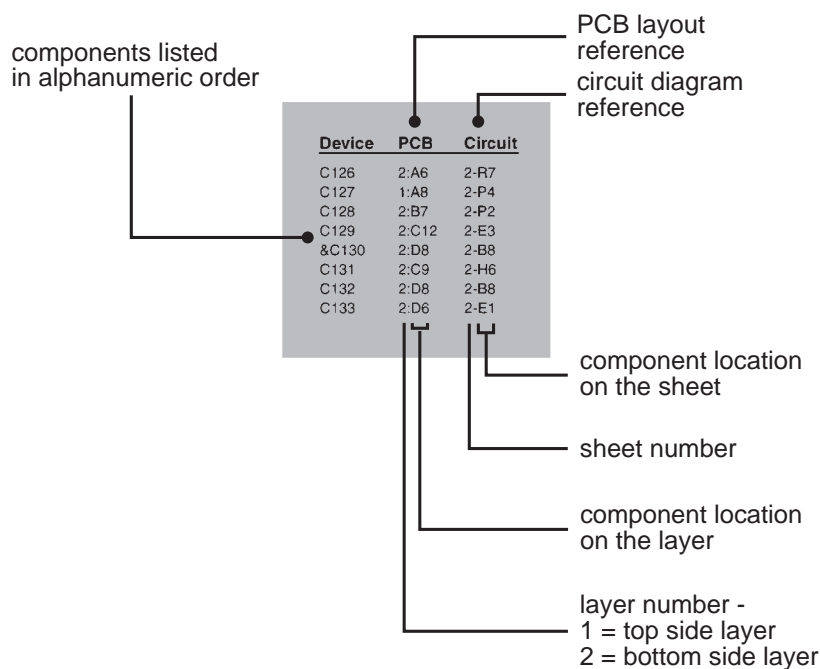

Using CAD Circuit Diagrams

Reading a CAD circuit diagram is similar to reading a road map, in that both have an alphanumeric border. The circuit diagrams in this manual use letters to represent the horizontal axis, and numbers for the vertical axis. These circuit diagram “grid references” are useful in following a circuit that is spread over two or more sheets.

When a line representing part of the circuitry is discontinued, a reference will be given at the end of the line to indicate where the rest of the circuitry is located, as shown below. The first digit refers to the sheet number and the last two characters refer to the location on that sheet of the continuation of the circuit (e.g. 1R3).

